

SPARE PARTS EXPLODED VIEW  
 GAS-WALL CONDENSING BOILERS  
 Model  
**TALIA GREEN SYSTEM EVO HP/EU**

R8203398-04 - 10/11/2020

1	3581421	TALIA GREEN SYSTEM EVO HP 45KW	07-2013	10-2015
2	3581422	TALIA GREEN SYSTEM EVO HP 65KW	07-2013	10-2015
3	3581423	TALIA GREEN SYSTEM EVO HP 85KW	07-2013	09-2015
4	3581424	TALIA GREEN SYSTEM EVO HP 100KW	07-2013	09-2015
5	3581425	TALIA GREEN SYSTEM EVO HP 115KW	07-2013	09-2015
6	3581426	TALIA GREEN SYSTEM EVO HP 150KW	07-2013	09-2015
7	3581570	TALIA GREEN SYSTEM EVO HP 45KW EU	11-2015	-
8	3581571	TALIA GREEN SYSTEM EVO HP 65KW EU	11-2015	-
9	3581572	TALIA GREEN SYSTEM EVO HP 85KW EU	11-2015	-
10	3581573	TALIA GREEN SYSTEM EVO HP 100KW EU	11-2015	-
11	3581574	TALIA GREEN SYSTEM EVO HP 115KW EU	11-2015	-
12	3581575	TALIA GREEN SYSTEM EVO HP 150KW EU	11-2015	-
Col	Reference	Model type	Begin	End

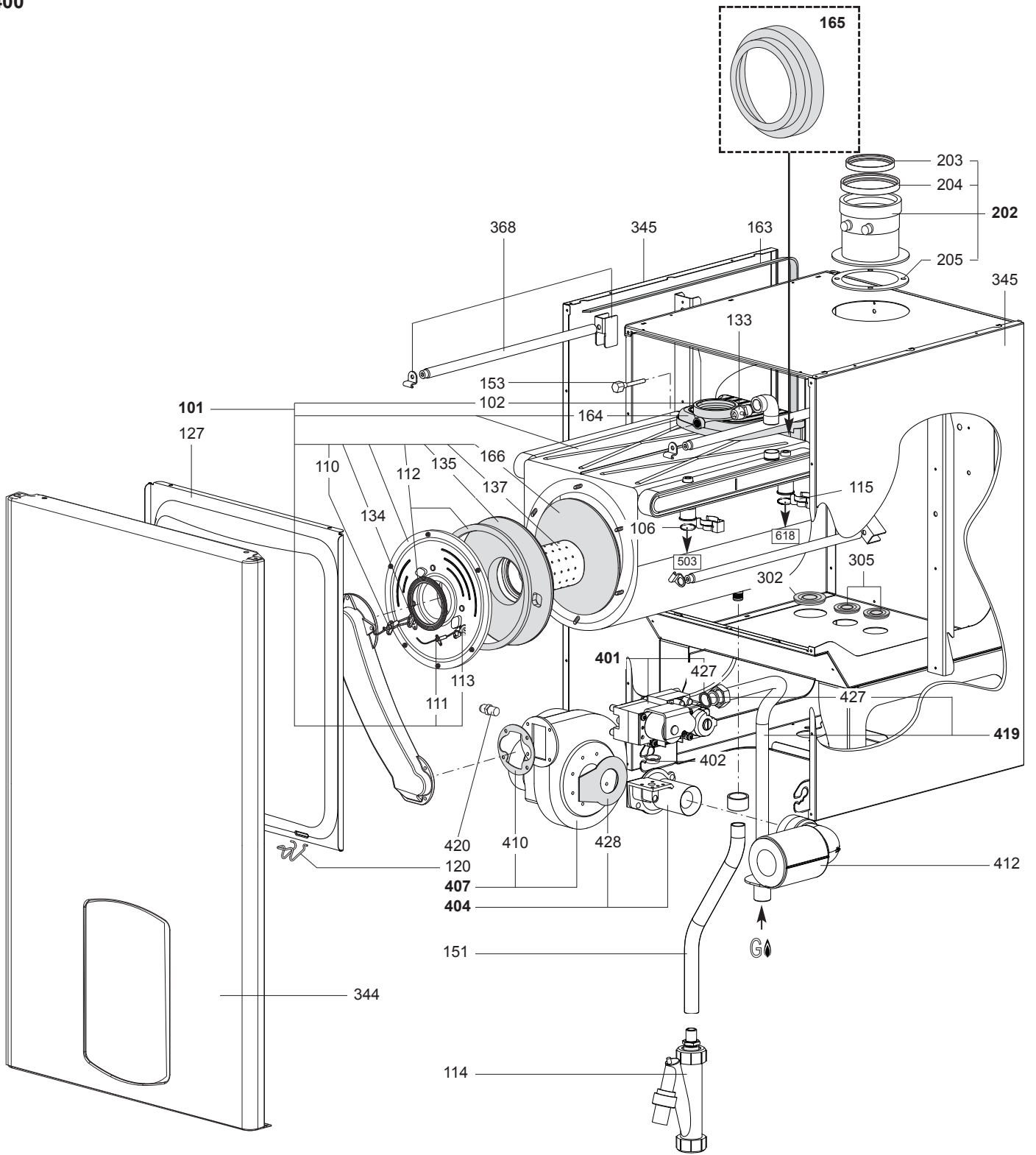



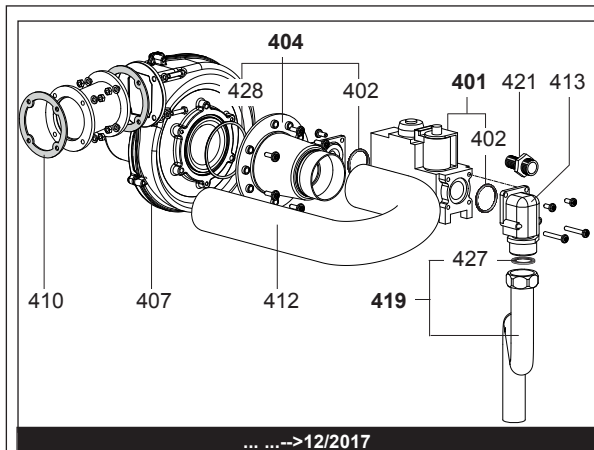
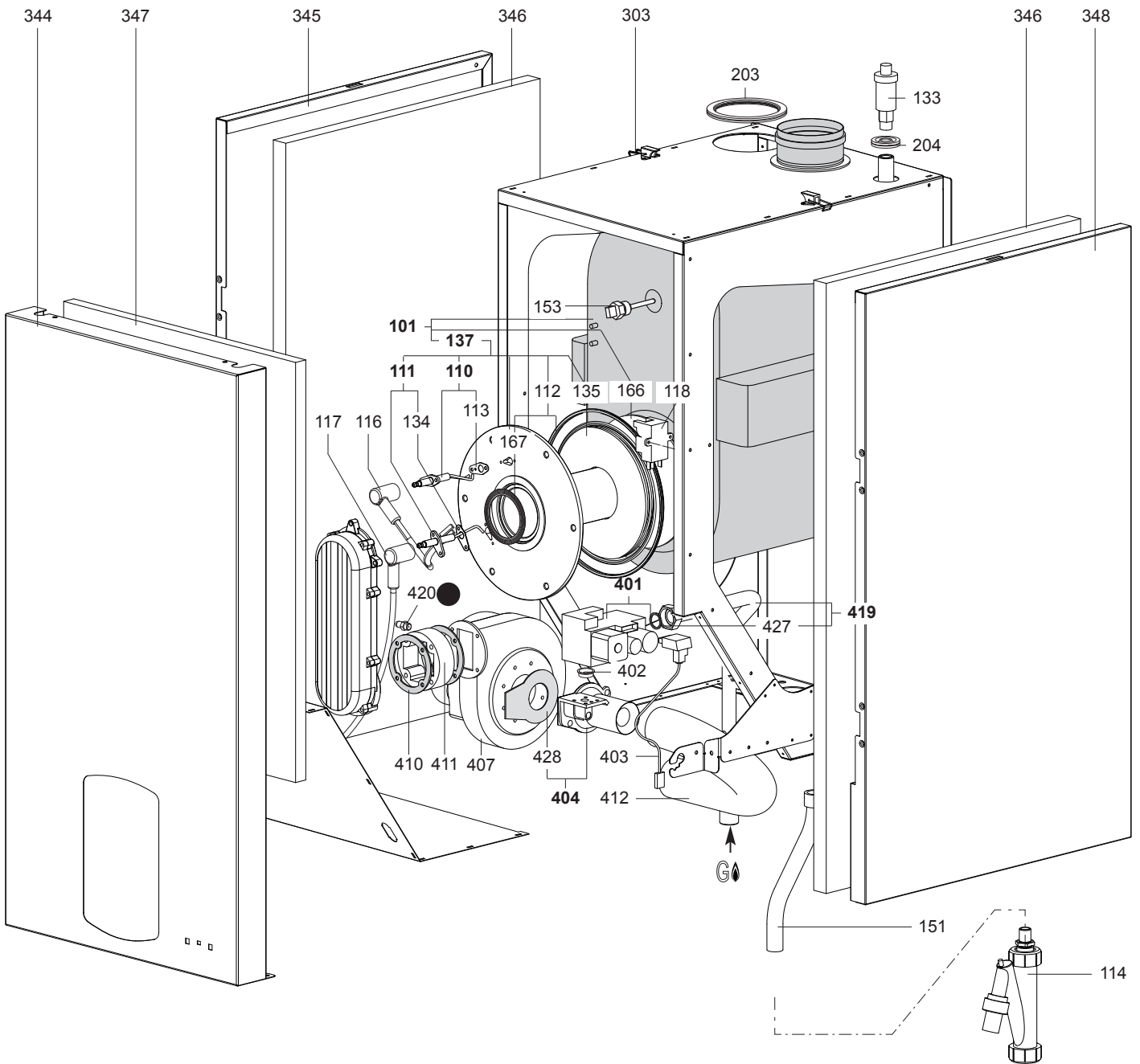

... ..->12/2017

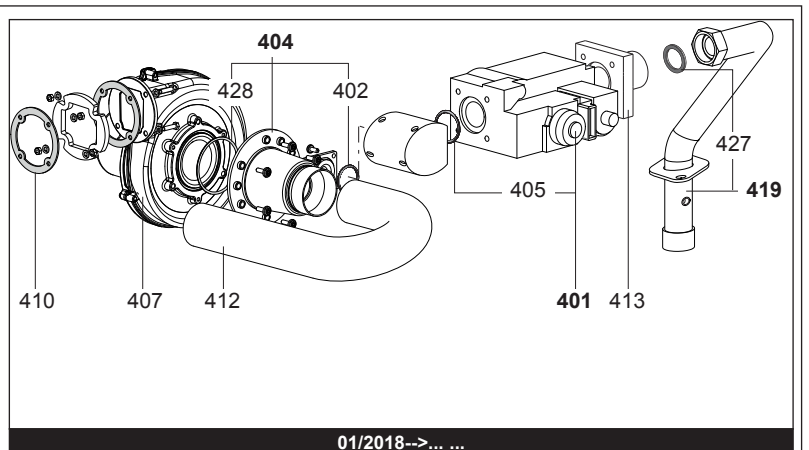

01/2018-->... ..



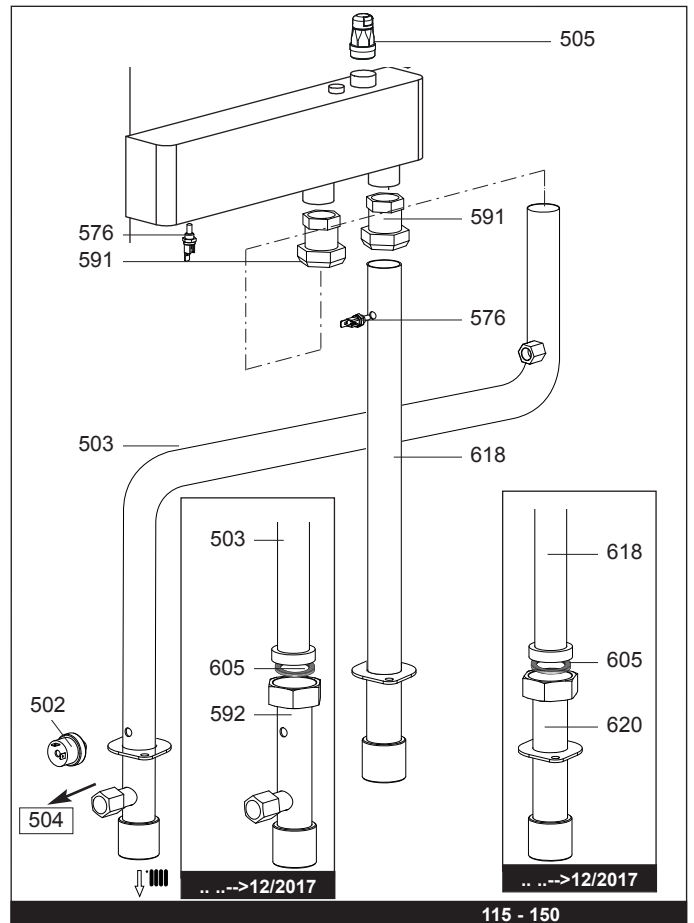
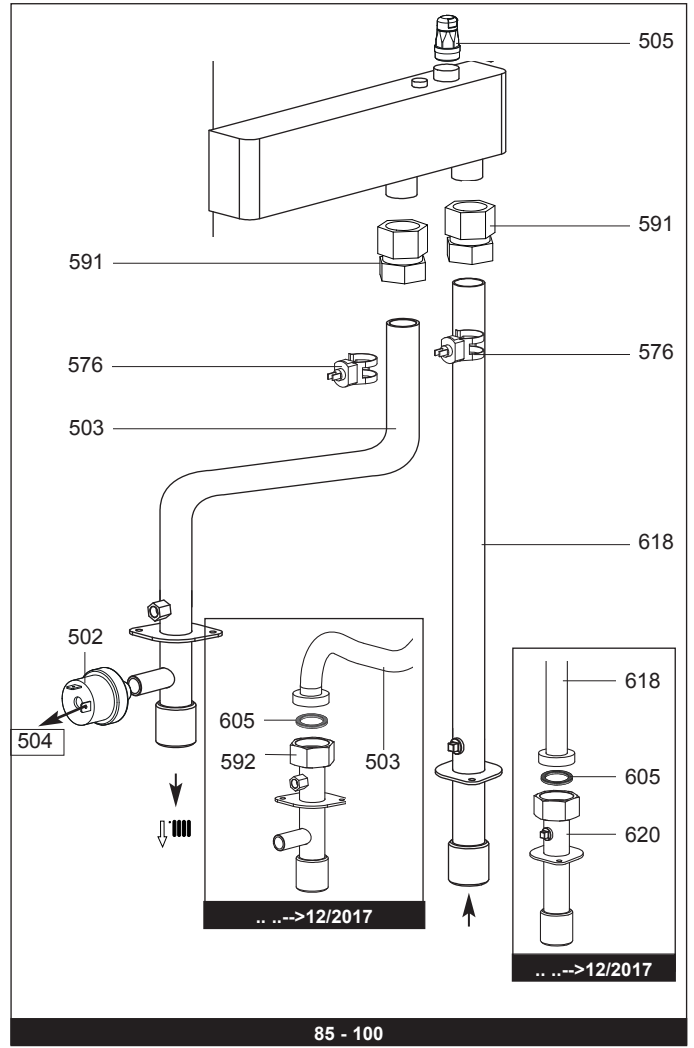
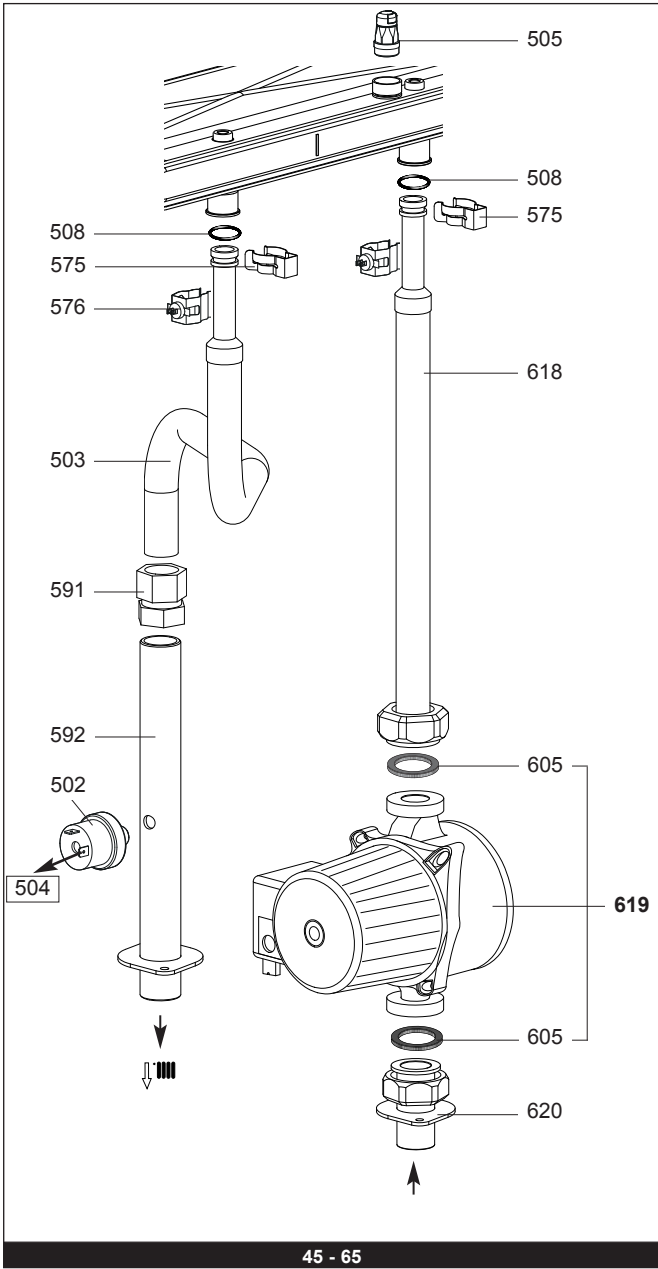



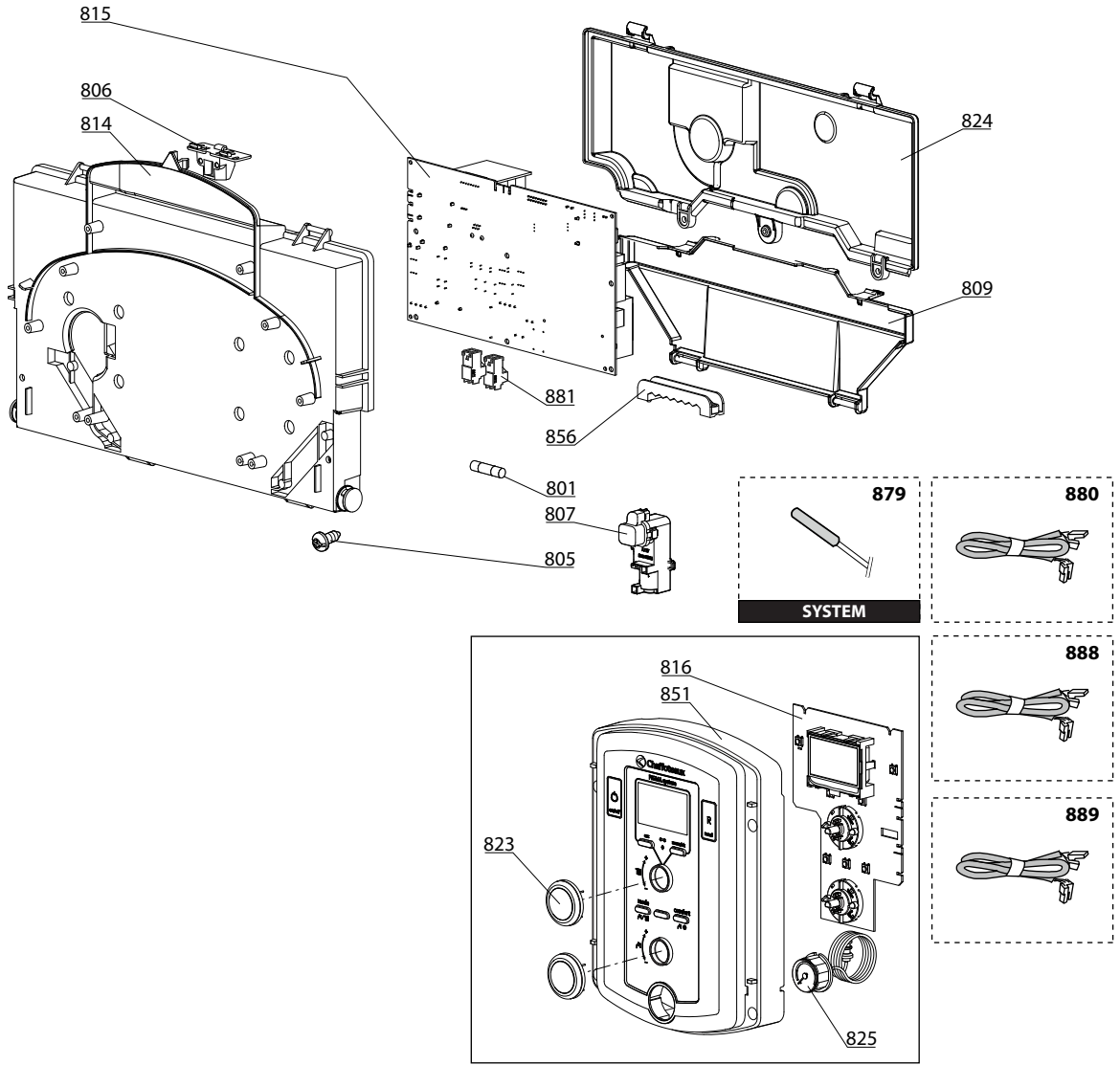

5000

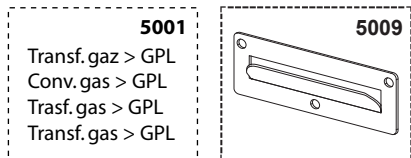





## LIST OF THE ABBREVIATIONS

HW .....	: Hot water.
CW .....	: Cold water.
C .....	: Ceramic resistance (normal heating).
Ca .....	: Ceramic resistance (accelerated heating)
TP .....	: Immersion heater.
1F .....	: With fittings.
2F .....	: Without fittings.
3F .....	: With fittings and another outlet connection.
AMI .....	: With mixing valve.
SMI .....	: Without mixing valve.
PUISS .....	: Power of th appliance.
PN .....	: Appliance with normal pression.
LP .....	: Appliance with low pression.
PV .....	: Appliance with variable power.
PF .....	: Appliance with fixed power.

## IDENTIFICATION PLATE

### SERIAL NUMBER

<b>10 Characters :</b>	04 05 125 011		
		Sequential number	
		Manufacturing day	
		Year of manufacture	
<b>11 Characters :</b>	1 95 065004 - 31		
Month of manufacture :		Technical number of the appliance	
from 1 to 9 → Jan. to Sep.,		Sequential number	
O → Oct., N → Nov.,		Year of manufacture	
D → Dec.			
<b>19 Characters :</b>	08 05 0013199 900640031		
Year of manufacture		Product reference	
Month of manufacture		Sequential number	
<b>20 Characters :</b>	3675007 XX 2 07 070 00315		
Product reference		Sequential number	
Millenium of manufacture		Manufacturing day	
		Year of manufacture	
<b>21 Characters :</b>	3675007 XX 07 070 0000315		
Product reference		Sequential number	
Year of manufacture		Manufacturing day	